

UNIVERSAL BELT TENSION METER - SM5

The SM5 Tension Meter is designed to measure the static tension of all belt types and materials and offers the following benefits:

- Simple one-button operation
- Accurate measurement results for optimal belt performance and life
- Save production and down time with quick readings
- Satisfy quality system requirements with traceable certification
- Integrates with our online calculation program - www.brecoflex.com

The purpose of pre-tensioning a belt is to maintain tension at all times throughout the belt during operation and depends on the belt drive type and peak loading. Minimizing pretension reduces bearing and shaft loading and preserves belt tensile safety factors. Minimum pre-tension is achieved when the belt does not sag or flap under peak running load. Maximum pre-tension is limited by the belt strength and machine design (shafts, bearings and frame).



Operation Instructions:

The SM5 Tension Meter is designed to measure the static tension of all belt types and materials and offers the following benefits:

1. **Press** button 1 second to activate meter.
2. **Aim** light beam at belt back with a sensor distance of 0.4 to 1.2 inches.
3. **Tap** belt to generate a vibration and SM5 will display a frequency.
4. **Wait** for "Ready" display and repeat measurement to confirm reading.
5. **Press** button 1 second to turn off or meter will auto power off after one minute.

Tips and Notes:

- For best results take readings on the belt back rather than tooth side or edge.
- Take a few readings to confirm consistency.
- Turn off nearby vibration interference sources while measuring.
- For long belt spans better readings and resolution can be achieved by temporarily shortening the vibrating free span **L** to around 1 meter.
- Frequency recommendations from calculations or our belt sizing program are initial theoretical settings and should be confirmed as optimal by observation for no signs of sag or flapping during operation. Once optimal tension is found then a new reading should be taken and recorded for future use.
- New belts conform to the geometry of a system and loose up to 10% pre-tension within the first few hours of run-in. Machine manufacturers often recommend different frequency settings for new and used belts for this reason.
- We offer a certification service for traceability. Calibration interval depends on use/environment and is up to the customer. Please contact customer service for pricing, turn around time and a return number.

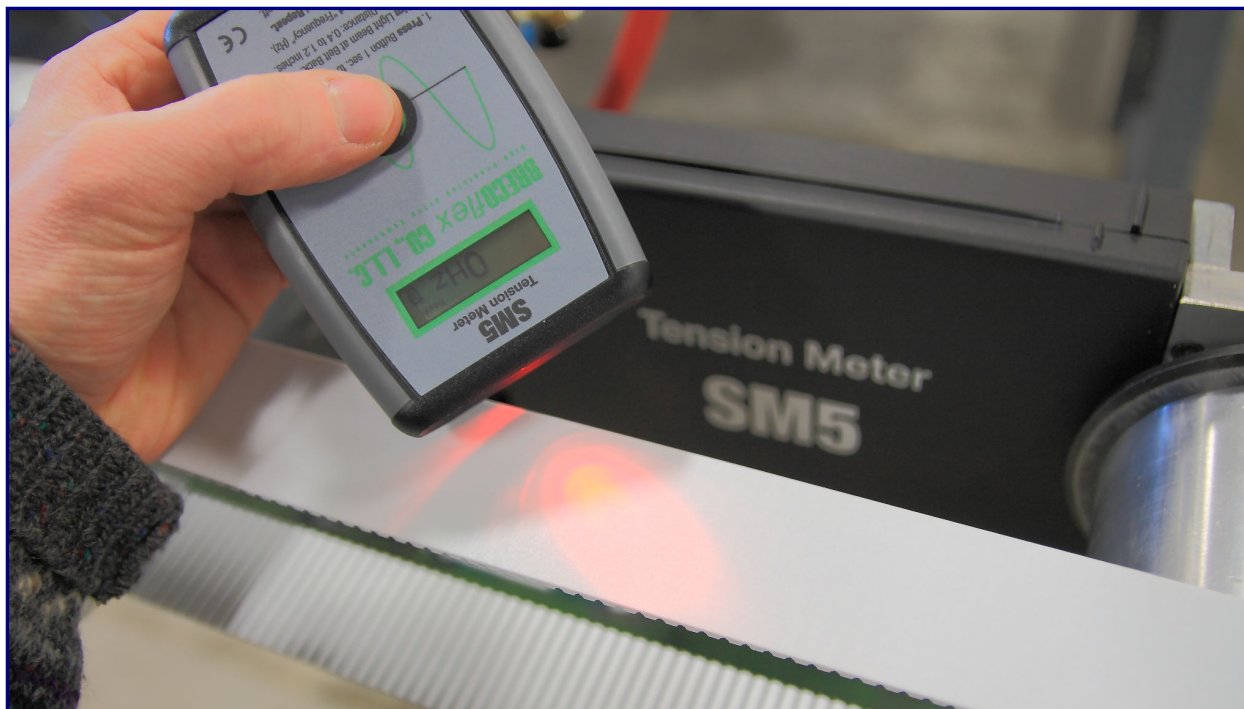

Check and Set Pre-tension:

Use the SM5 to check belt pre-tension

Calculate the pre-tension **Fv** using the frequency **f** read from the meter.

$$F_v = f^2 \cdot L^2 \cdot 4 \cdot m \cdot b$$

Fv [N] current pre-tension in Newtons (1 lbf = 4.45N)
 f [Hz] frequency read from the meter
 L [m] free vibrating span length in meters
 m [Kg/m/cm] belt mass in kilograms per meter of length per centimeter belt width
 b [cm] belt width in cm (1" = 2.54cm) (1cm = 10mm)

Use the SM5 to set belt pre-tension

Calculate the frequency **f** required to achieve a target pre-tension **Fv**. Alternately use our online calculation program recommendation.

$$f = \sqrt{\frac{F_v}{L^2 \cdot 4 \cdot m \cdot b}}$$

f [Hz] frequency reading
 Fv [N] target pre-tension in Newtons (1 lbf = 4.45N)
 L [m] free vibrating span length in meters
 m [Kg/m/cm] belt mass in kilograms per meter of length per centimeter belt width
 b [cm] belt width in cm (1" = 2.54cm) (1cm = 10mm)

Belt Mass - Steel Cord [kilograms per meter of belt length per centimeter of belt width]					
Belt Pitch	Single Sided	Double Sided	Belt Pitch	Single Sided	Double Sided
AT3	0.022	-	T2	0.012	-
AT5	0.033	0.041	T2.5	0.017	-
ATL5	0.037	-	T5	0.021	0.028
ATK5K6	0.034	-	TK5K6	0.024	-
AT10	0.058	0.076	T10	0.045	0.058
ATL10	0.068	-	TK10K6	0.046	-
ATK10K6	0.059	0.077	TK10K13	0.057	-
ATK10K13	0.066	-	T20	0.074	0.100
BAT10/BATK10	0.059	-	MXL	0.012	-
ATP10	0.060	0.064	T1/5" = XL	0.024	-
SFAT10	0.058	-	T3/8" = L	0.035	-
ATS15	0.100	0.118	T1/2" = H	0.043	0.052
BAT15/BATK15	0.084	-	T7/8" = XH	0.104	-
ATP15	0.080	0.088	HTD 3M HP	0.031	-
SFAT15	0.088	-	HTD 5M HP	0.041	-
AT20	0.096	0.125	HTD 5M HF	0.034	-
ATL20	0.110	-	HTD 8M HP	0.063	-
ATK20K13	0.995	-	HTD 8M HF	0.054	-
SFAT20	0.096	-	HTD 14M HP	0.113	-

Belt Drive Type:

Select belt drive type below to determine required pretension **Fv** as a function of peripheral force. These values are a starting point and tension should be increased as necessary to eliminate sag or flapping during peak peripheral belt loading.

Two Pulley Drive	
Number of belt teeth	Pre-tension Fv
< 60 teeth	$F_v = 1/3$ peripheral force
60 to 150 teeth	$F_v = 1/2$ peripheral force
> 150 teeth	$F_v = 2/3$ peripheral force

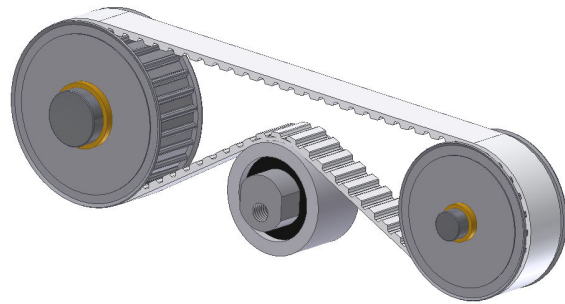

Linear Drive	
Belt Span	Pre-tension Fv
Any	$F_v =$ peripheral force

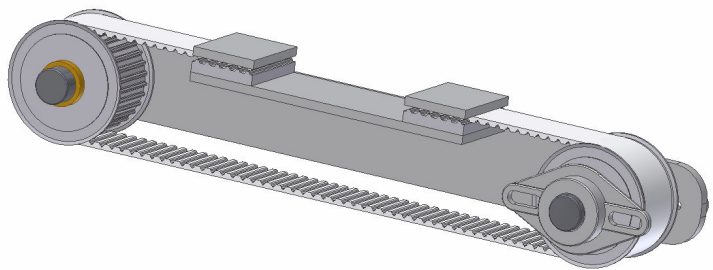

Multiple Pulley Drive	
Belt Span	Pre-tension Fv
Taut length < slack	$F_v =$ peripheral force
Taut length > slack	$F_v >$ peripheral force

